



EM Series
PARTS
BOOK

Version:06000V3

THINK BEYOND



INDEX

01.Cover-Base

4

02.Cover-Head

6

03.Main Axis

8

04.Thread-Hook and Jumping
Assembly

12

05.Color Change System

14

06.Lower Shaft Arm

16

07.Y-axis Drive System

18

08.X-axis Drive System

20

09.Needle Bar Case

22

10.Middle Thread-Course

24

11.Control Panel / Support Arm

26

12.Thread Tray and Thread Stand

28

13.Upper Thread Module

30

14. Frames and Bracket

32

15.Electronic components

34

16.CAP STAND FRAME

36

General View

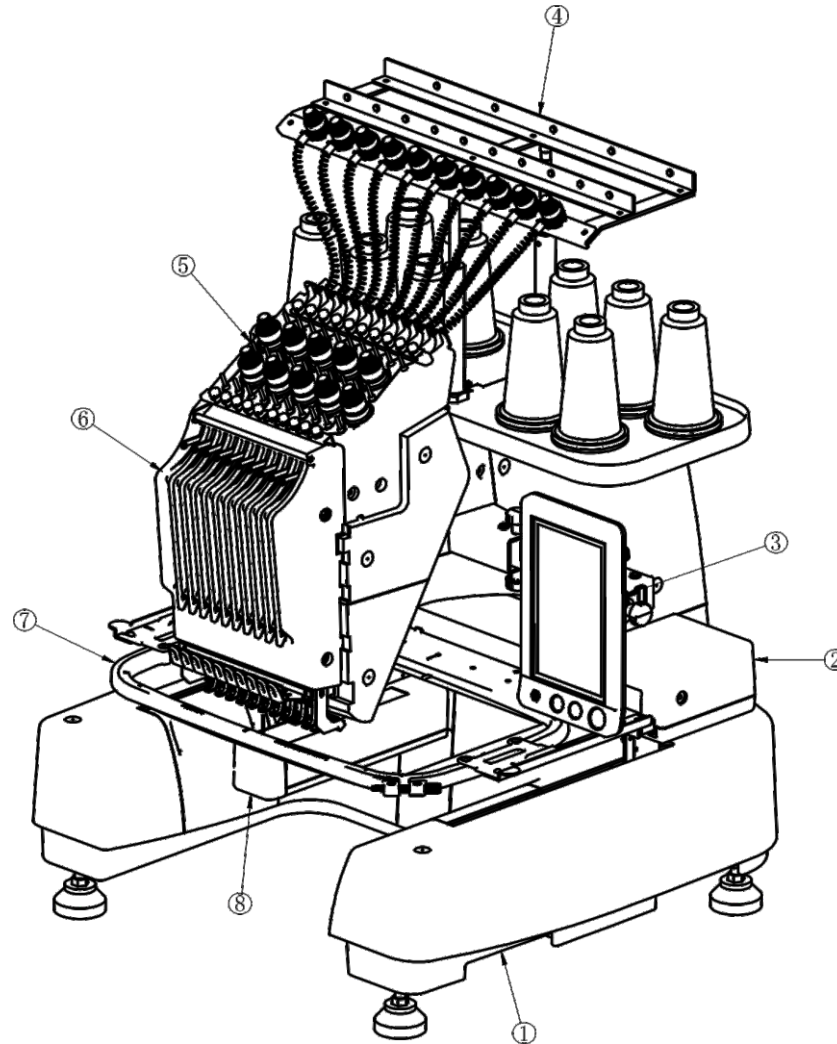

General View	
NO	Name
1	Bast
2	Driver Assembly-X-EM
3	Panel-Support
4	Thread Tray and Thread Stand
5	Table Guard Cover
6	Middle Thread-Course
7	Frames Bracket
8	Rotary Hook Base

01. Cover-Base

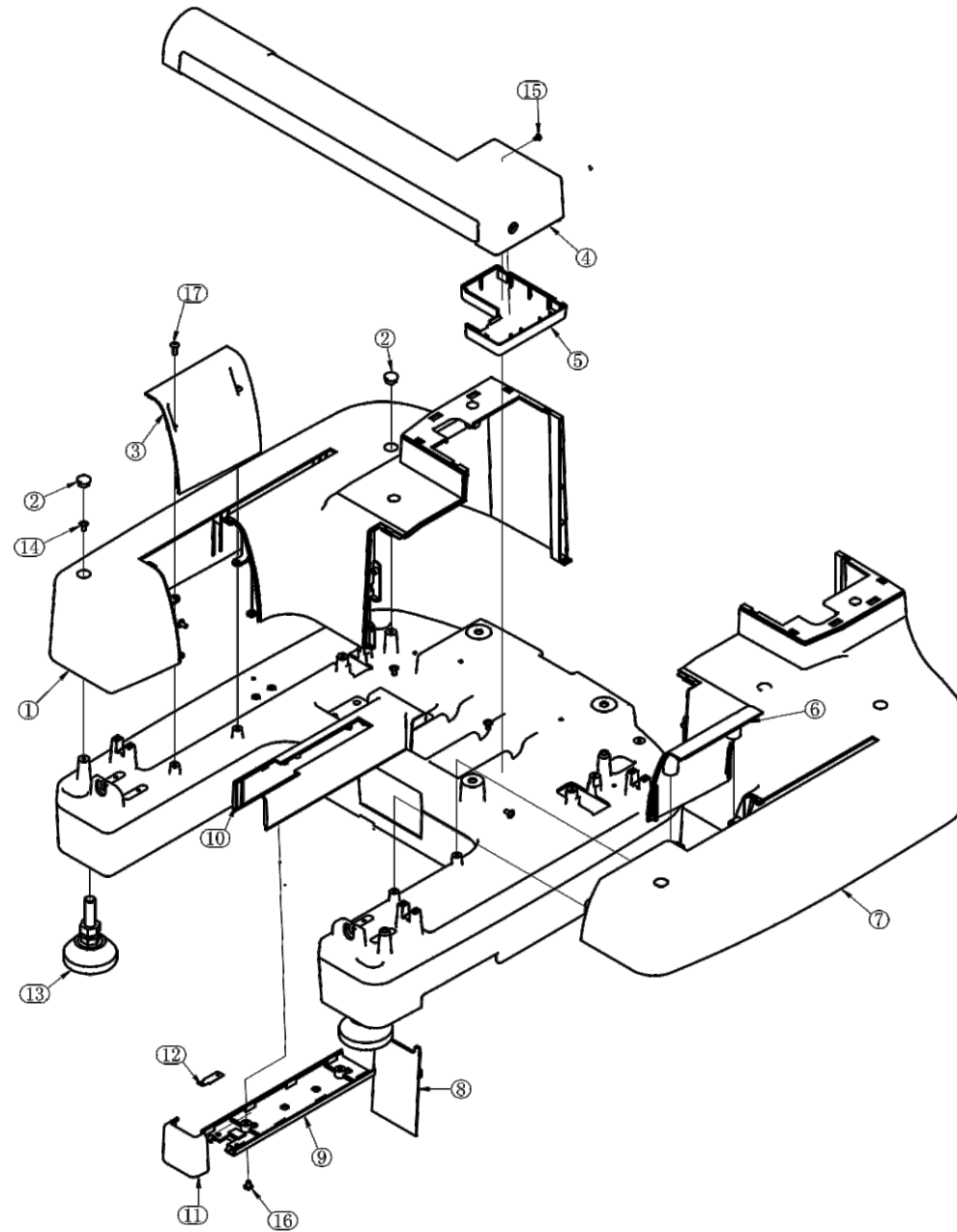



01. Cover-Base

06010V3

No.	Serial No.	Part name	Remark
1	3006010201	Cover-Base-Left	
2	3006010241	Screw Cap	
3	3006010202	Small Cover for Left Side	
4	3006010231	Cover-X-direction Drive-EM	
5	3006010232	Lower Cover-X-EM	
6	3006010204	Small Cover for Right Side	
7	3006010203	Cover-Base-Right	
8	3006010205	Middle Cover Plate-Base-EM	
9	3006010222	Cover-Rotary Hook Arm-Lower-EM	

No.	Serial No.	Part name	Remark
10	3006010221	Cover-Rotary Hook Arm-Top-EM	
11	3006010223	Cover-Rotary Hook-EM	
12	3006021116	Rotary Hook Cover Positioned Spring	
13	80270831-304	Support Base Foot-EM	
14	80746408	Screw M4*8	
15	80700107	Screw-STM3*8	
16	80746406	Screw M4*6	
17	80746412	Screw M4*12	

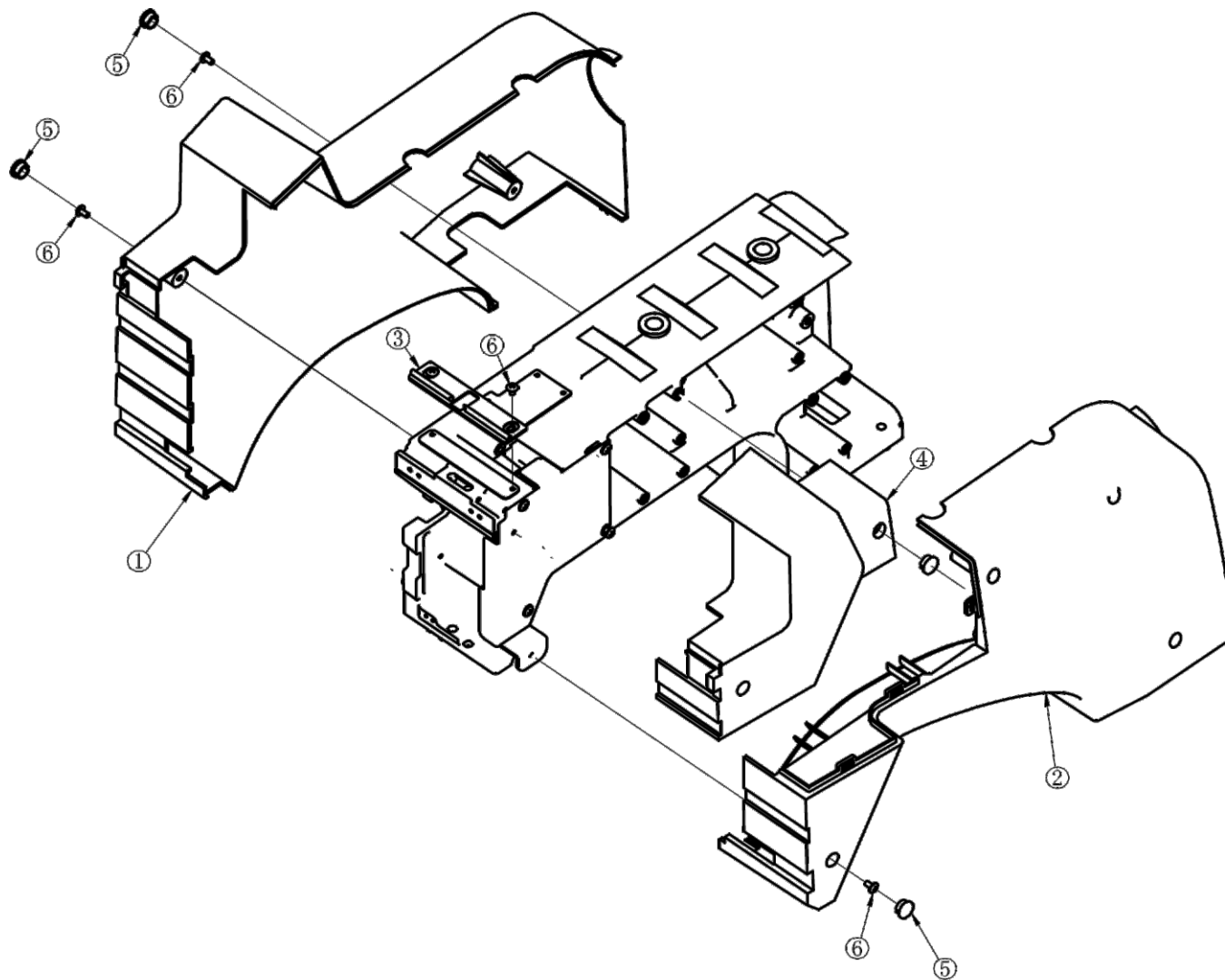



02. Cover-Head

06020V3

No.	Serial No.	Part name	Remark
1	3006010211	Cover-Head-Left	
2	3006010212	Cover-Head-Right	
3	3006041103	Guide Plate-Take-up Level-EM	

No.	Serial No.	Part name	Remark
4	3006010213	Cover-Head-Right Front-EM	
5	3006010241	Screw Cap	
6	80746408	Screw M4*8	

03. Main Axis-1

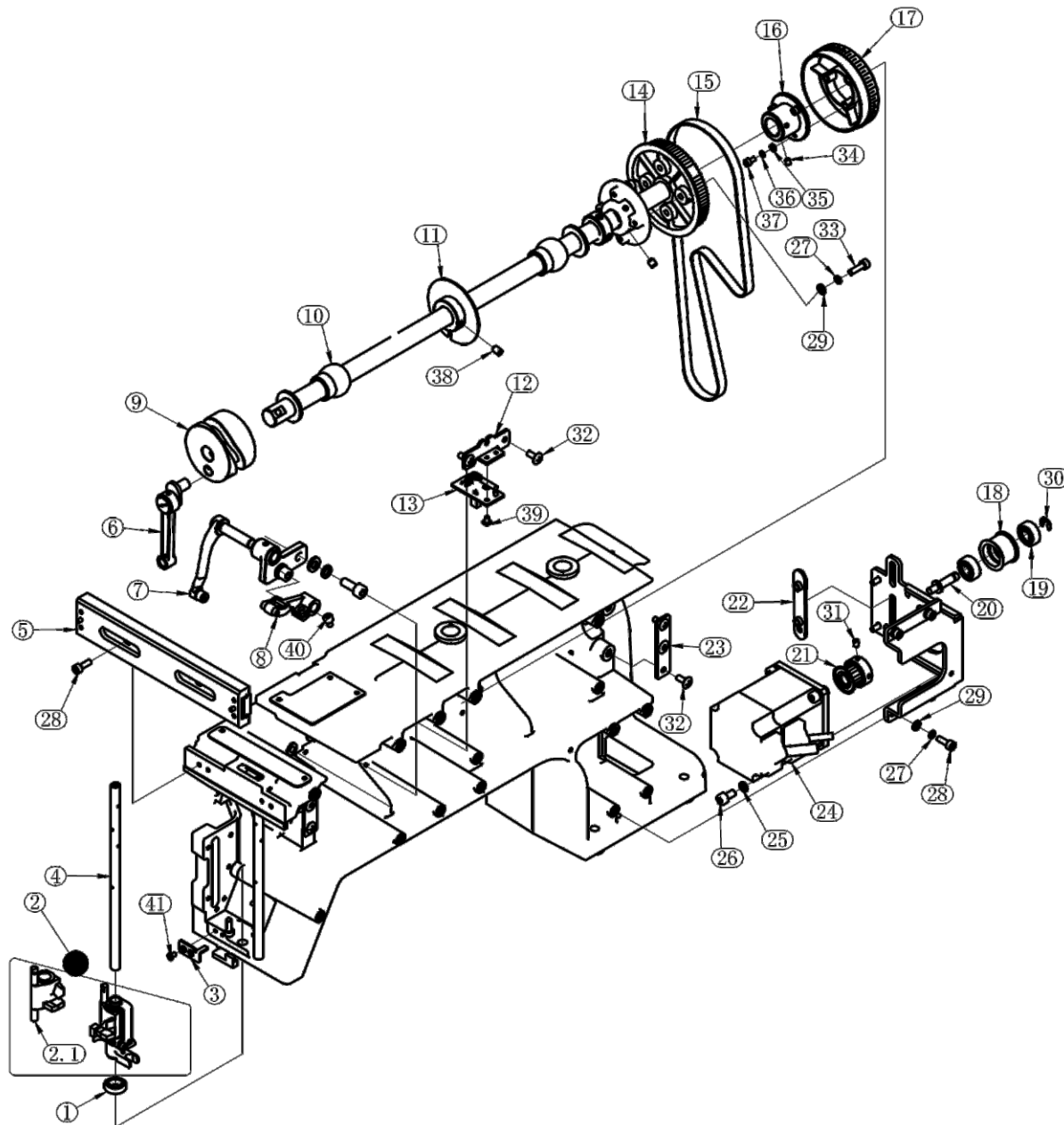



03. Main Axis-1

06030V3

No.	Serial No.	Part name	Remark
1	80037921	Bearing-7.24-17-4	
2	3006040463	Reciprocator Components-EM	
2.1	03040305	Reciprocator-EM	
3	3006040102	Location Plate-Lower Guide Rail Bearing-EM	
4	3006040121	Shaft-Needle Bar Drive-OD7.24-EM	
5	3006040111	Head Guide Rail-10	
6	3006040460	Connecting Rod-Needle Bar Drive	
7	03041193	Take-up Lever Main Connecting Rod Components	
8	3006041160	Take-up Lever Driver	
9	03040203EA	Take up Cam-Head-Copper	
10	3006041211	Oil Bearing-SR13-ID15	
11	03041207	Zero Position Baffle	
12	3006041221	Mount Plate-Zero Position Sensor	
13	3006152104	Zero Position Sensor-J8	
14	3006041204	Belt Pulley-Upper Shaft-EM	
15	3006040191	Timing Belt-Main Shaft-EM (3M-669-8)	
16	3006041207	Knob Base-Main Shaft-EM	
17	3006041213	Main Shaft Knob	
18	3006041234	Tension Pulley-Main Shaft-EM	
19	80030622	Deep Groove Ball Bearing-626ZZ	
20	3006041232	Tension Pulley Shaft-Main Shaft-EM	

No.	Serial No.	Part name	Remark
21	3006041292	Synchronous Pulley-Main Shaft-EM	
22	3006041233	Adjusting Plate--Main Shaft Tension Pulley-EM	
23	3006041212	Pressing Plate-Oil Bearing-Upper Shaft	
24	3006041296	Main Motor-Main Shaft-BLDC60	
25	80900518	M5 Spring Washer	
26	80813510	M5*10 Hexagon Socket Caphead Screw	
27	80900418	M4 Spring Washer	
28	80813412	M4*12 Hexagon Socket Caphead Screw	
29	80900401	M4 Plain Washer	
30	80030671	E-ring-6	
31	80880406	M4*6 Hexagon Socket Set Screw	
32	80746410	Screw M4*10	
33	80813414	M6*14 Hexagon Socket Caphead Screw	
34	80880405	M4*5 Hexagon Socket Set Screw	
35	80900301	M3 Plain Washer	
36	80900318	M3 Spring Washer	
37	80813410	M4*10 Hexagon Socket Caphead Screw	
38	80880508	M5*8 Hexagon Socket Set Screw	
39	80746306	Screw M3*6	
40	80813406	M4*6 Hexagon Socket Caphead Screw	
41	80860326	M3*6 Flat Head Philips Screw	

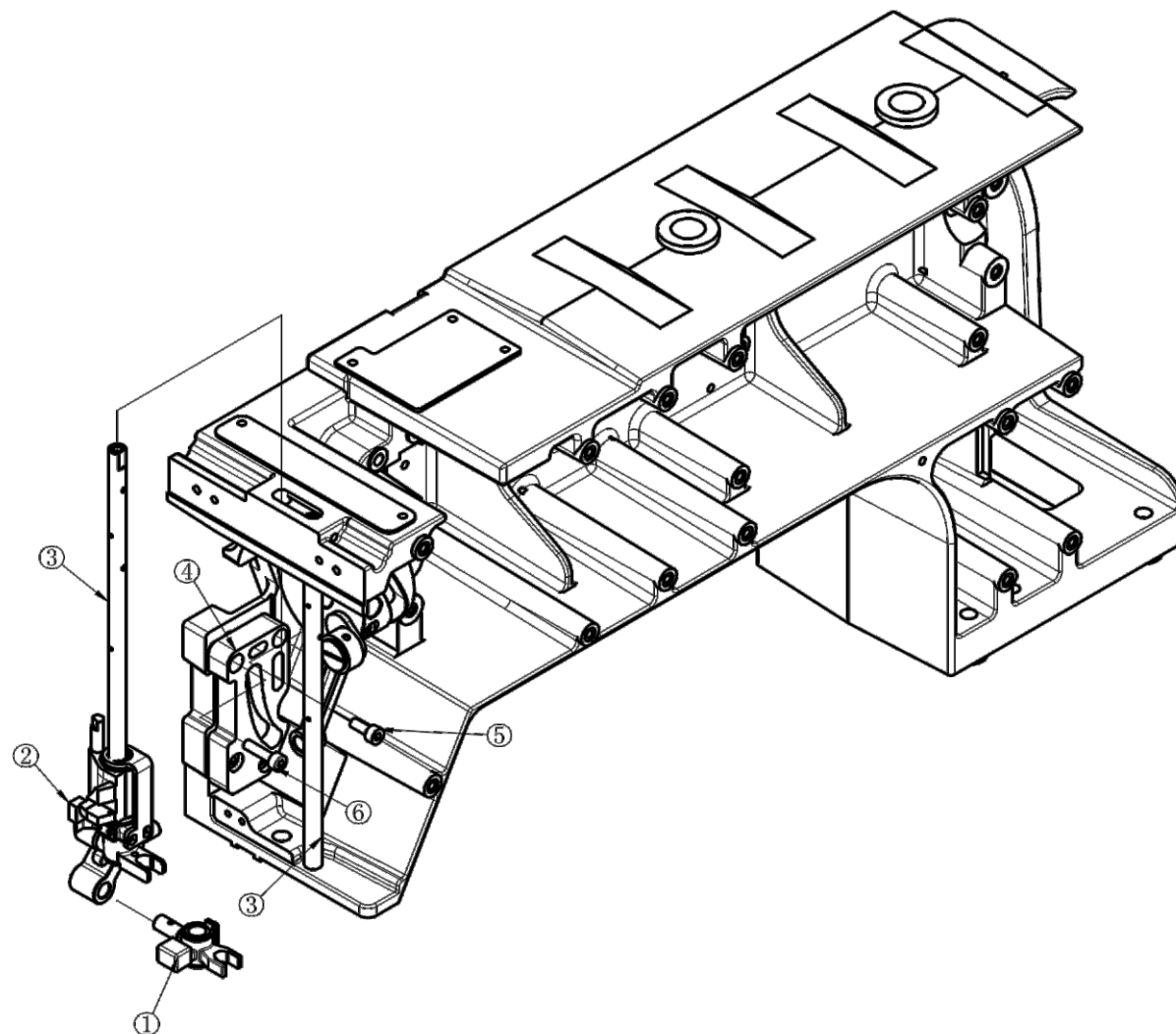



03. Main Axis-2

06031V3

No.	Serial No.	Part name	Remark
1	3006040464	Presser Foot Drive Components-EM	
2	3006040463	Reciprocator Unit	
3	3006040121	Shaft-Reciprocator-OD7.24-EM	

No.	Serial No.	Part name	Remark
4	3006040411	Guide Holder-Side Presser Foot-EM	
5	80810410	M4*10 Hexagon Socket Caphead Screw	
6	80810416	M4*16 Hexagon Socket Caphead Screw	

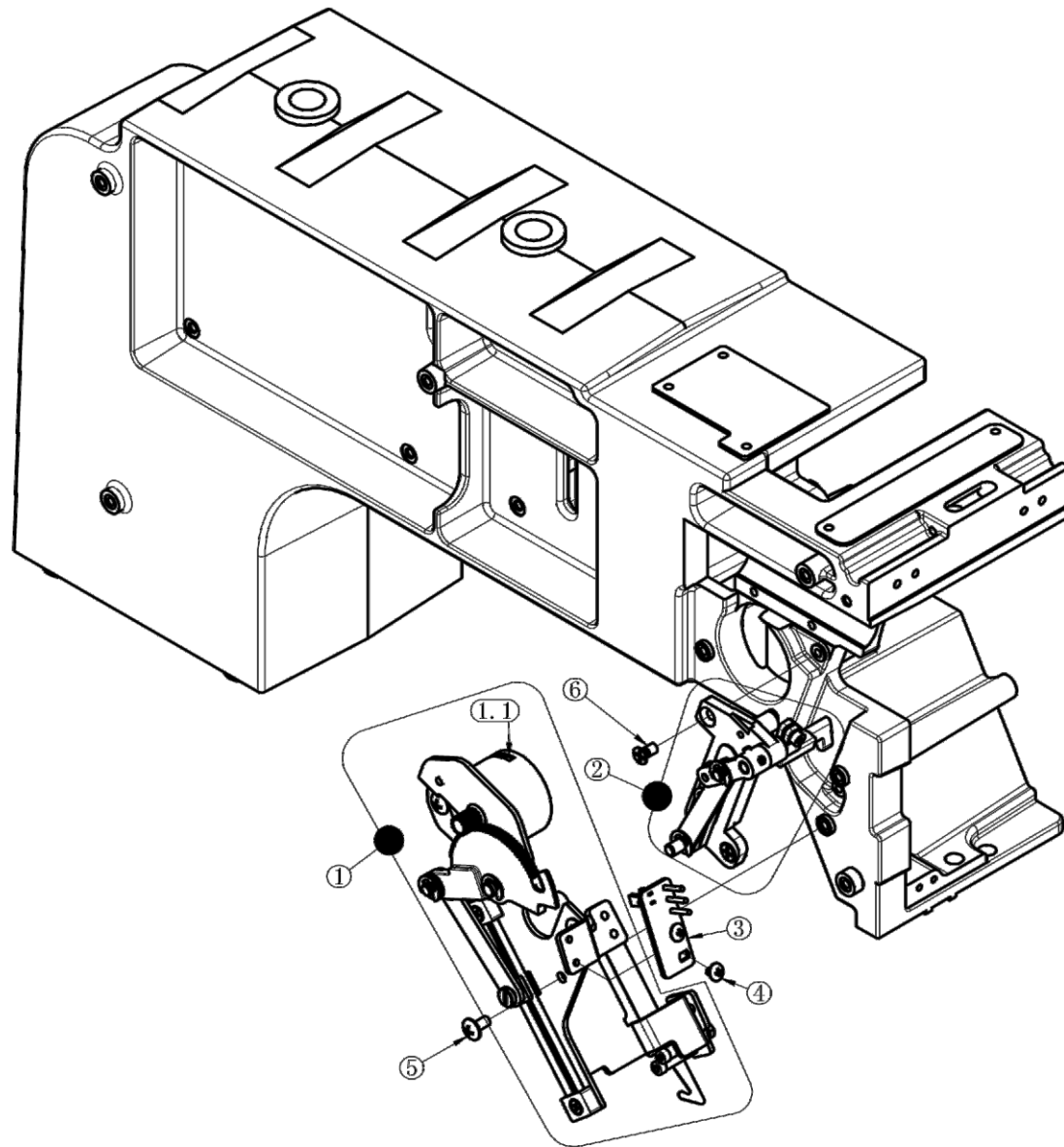



04. Thread-Hook and Jumping Assembly

06040V3

No.	Serial No.	Part name	Remark
1	3006040660	Hook Unit-EM	
1.1	3006040696	Stepper Motor-PM35	
2	3006040760	Jump Drive Assembly-EM	
3	3006152107	Sensor Plate for Thread-Hook	

No.	Serial No.	Part name	Remark
4	380746304	Screw M3*4	
5	80746408	Screw M4*8	
6	80860410	Hat Head Philips Screw M4*10	

05. Color Change System

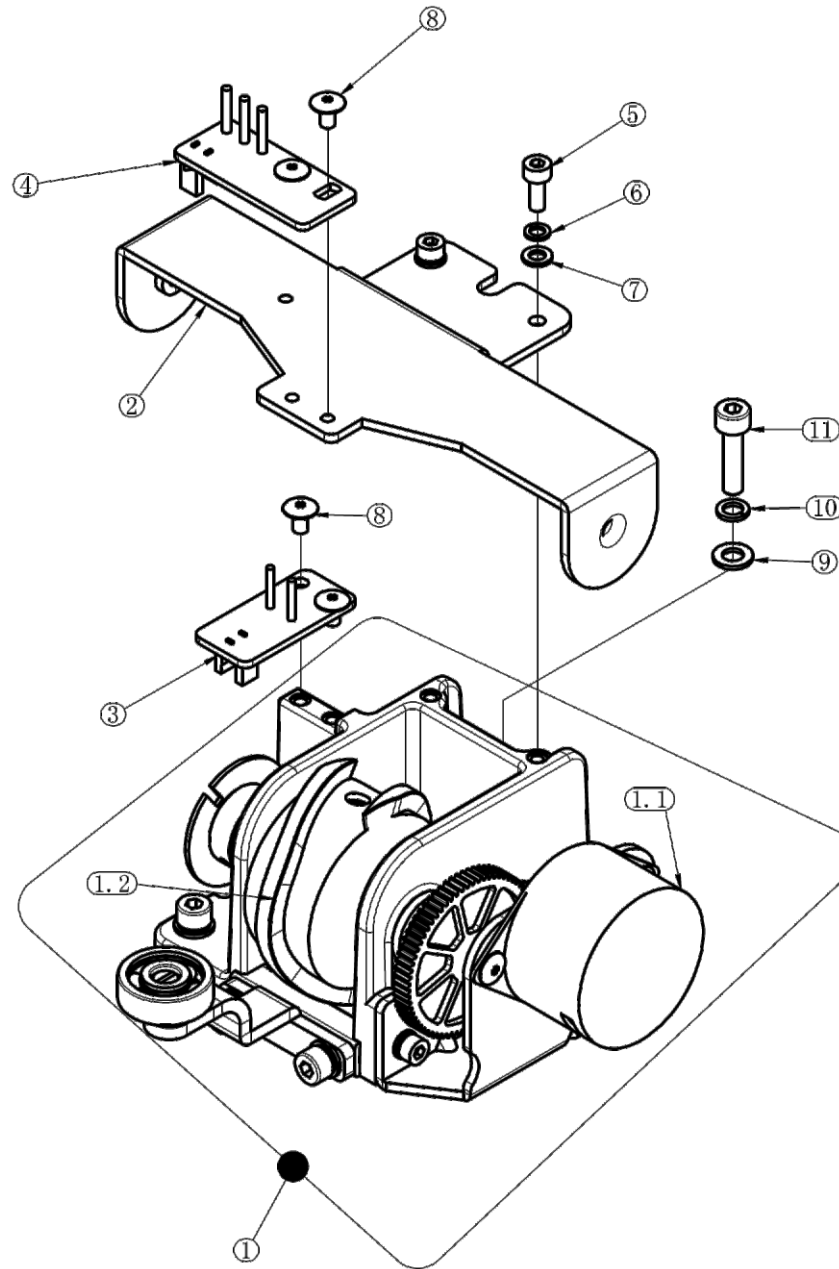



05. Color Change System

06050V3

No.	Serial No.	Part name	Remark
1	3006040561	Color Change Assembly	
1.1	3006040596	Stepper Motor-PM35	
1.2	3006040521	Cam-Color Change-EM	
2	3006040512	Bracket Plate-Needle Position Sensor-EM	
3	3006152102	Sensor--Color Change-JP5	
4	3006152103	Sensor-Needle Position-JP6	
5	80813308	M3*8 Hexagon Socket Caphead Screw	

No.	Serial No.	Part name	Remark
6	80900318	M3 Spring Washer	
7	80900301	M3 Plain Washer	
8	80746305	Screw M3*5	
9	80900401	M4 Plain Washer	
10	80900418	M4 Spring Washer	
11	80813416	M4*16 Hexagon Socket Caphead Screw	

06. Lower Shaft Arm

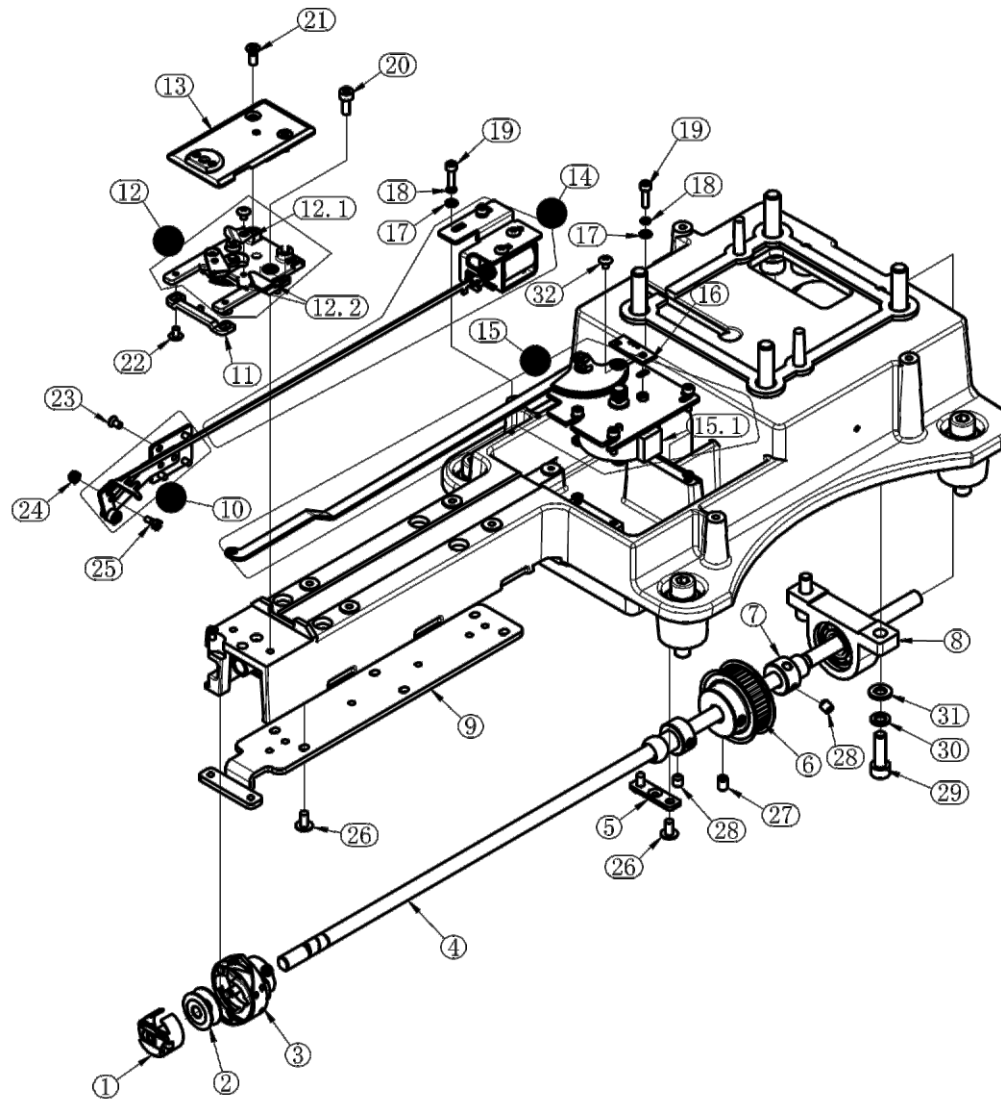



06. Lower Shaft Arm

06060V3

No.	Serial No.	Part name	Remark
1	80620301	Bobbin Case	
2	80620302	Bobbin	
3	80620291	Rotary Hook-KHS12-RYP	
4	3006021102	Rotary Hook Shaft-ID7.94-EM	
5	3006021114	Pressing Plate-Oil Bearing-Lower Shaft-EM	
6	3006021190	Pulley-Lower Shaft-EM	
7	80037901	Bearing Collar-ID7.94OD12	
8	3006021160	Bearing Base-Lower Shaft-EM	
9	3006021115	Stand-Cap Driver Guide Rail-EM	
10	3006021560	Picker Assembly-EM	
11	03021322	Rotary Position Hook	
12	3006021361	Trimming Seat Assembly-EM	
12.1	02101233	Fixed Knife Shrapnel	
12.2	02101282	Scissors Kit	
13	3006021112VA	Needle Plate-EM	
14	3006021561	Picker Solenoid Assembly-EM	
15	3006021260	Trimming Motor Assembly-EM	
15.1	3006021296	Stepper Motor-PM42	

No.	Serial No.	Part name	Remark
16	3006152105	Sensor Plate for Trimming-J6	
17	80900301	M3 Plain Washer	
18	80900318	M3 Spring Washer	
19	80813312	M3*12 Hexagon Socket Caphead Screw	
20	80813410	M4*10 Hexagon Socket Caphead Screw	
21	80860410	M4*10 Flat Head Philips Screw	
22	80740306	Screw M3*6-Small Head Philips	
23	80860326	M3*6 Flat Head Philips Screw	
24	80900332	M3 Nut	
25	3006021504	Screw M2.5*4-3*3	
26	80746408	Screw M4*8	
27	80880508	M5*8 Hexagon Socket Set Screw	
28	80880506	M5*6 Hexagon Socket Set Screw	
29	80813620	M6*20 Hexagon Socket Caphead Screw	
30	80900618	M6 Spring Washer	
31	80900601	M6 Plain Washer	
32	80740304	Screw M3*4-Small Head Philips	

07. Y-axis Drive System

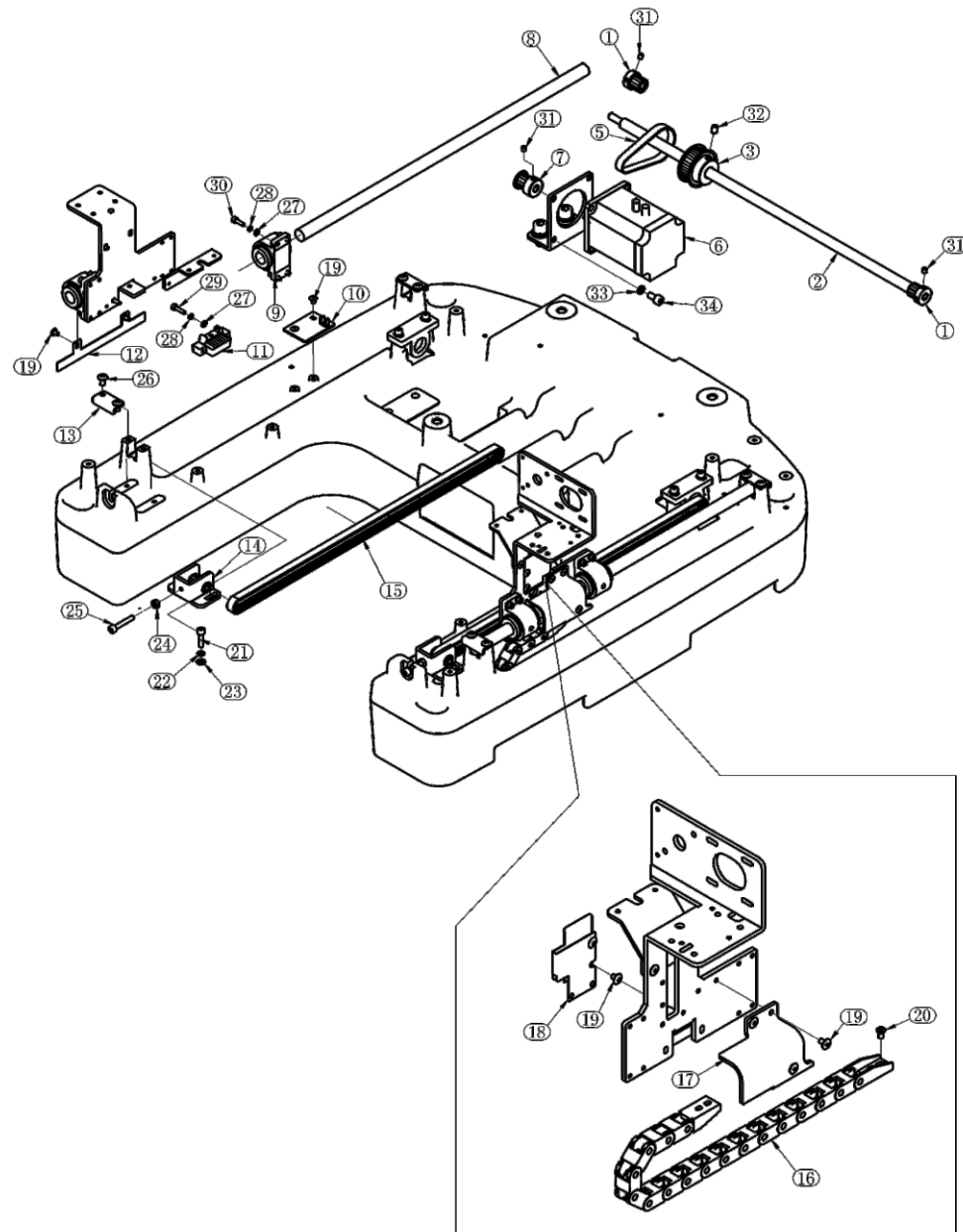



07. Y-axis Drive System

06070V3

No.	Serial No.	Part name	Remark
1	3006105194	Driven Pulley-Y-EM	
2	3006105124	Drive Shaft-Y-EM	
3	3006105193	Pulley-36-3M-9BF-22	
4	3006105123	Y Motor Base	
5	3006105195	Timing Belt-Drive-Y (3M-180-8)	
6	3006105190	Stepper Motor-60HS3A76-606	
7	3006105192VA	Pulley-16-3M-10BF-20	
8	3006105111	Shaft-Guide Rail-D12-Y-EM	
9	3006105162	Bearing Base Components-Y-Guide Rail-EM	
10	3006152106Y	Sensor-YLimit	
11	3006105115	Pressing Plate-Timing Belt-Y-EM	
12	3006105113	Baffle-Limit-Y-EM	
13	3006105117	Pressing Plate-Limit-Y-EM	
14	3006105161	Tensioner for Y Belt-EM	
15	3006105196	Timing Belt-Y Axis-EM (3M-735-8)	
16	3006105163	Nylon Chain Assembly-Y-EM	
17	3006105114	Connecting Plate-Nylon Chain-EM	

No.	Serial No.	Part name	Remark
18	3006105116	Thread-Crimping Plate-Y-EM	
19	80746304	Screw M3*4-Small Head Philips	
20	80860329	M3*10 Flat Head Philips Screw	
21	80813416	M4*16 Hexagon Socket Caphead Screw	
22	80900418	M4 Spring Washer	
23	80900401	M4 Plain Washer	
24	80900428	M4 Nut	
25	80813525	M5*25 Hexagon Socket Caphead Screw	
26	80746408	Screw M4*8	
27	80900301	M3 Plain Washer	
28	80900318	M3 Spring Washer	
29	80813312	M3*12 Hexagon Socket Caphead Screw	
30	80813310	M3*10 Hexagon Socket Caphead Screw	
31	80880405	M4*5 Hexagon Socket Set Screw	
32	80880508	M5*8 Hexagon Socket Set Screw	
33	80900518	M5 Spring Washer	
34	80813510	M5*10 Hexagon Socket Caphead Screw	

08. X-axis Drive System

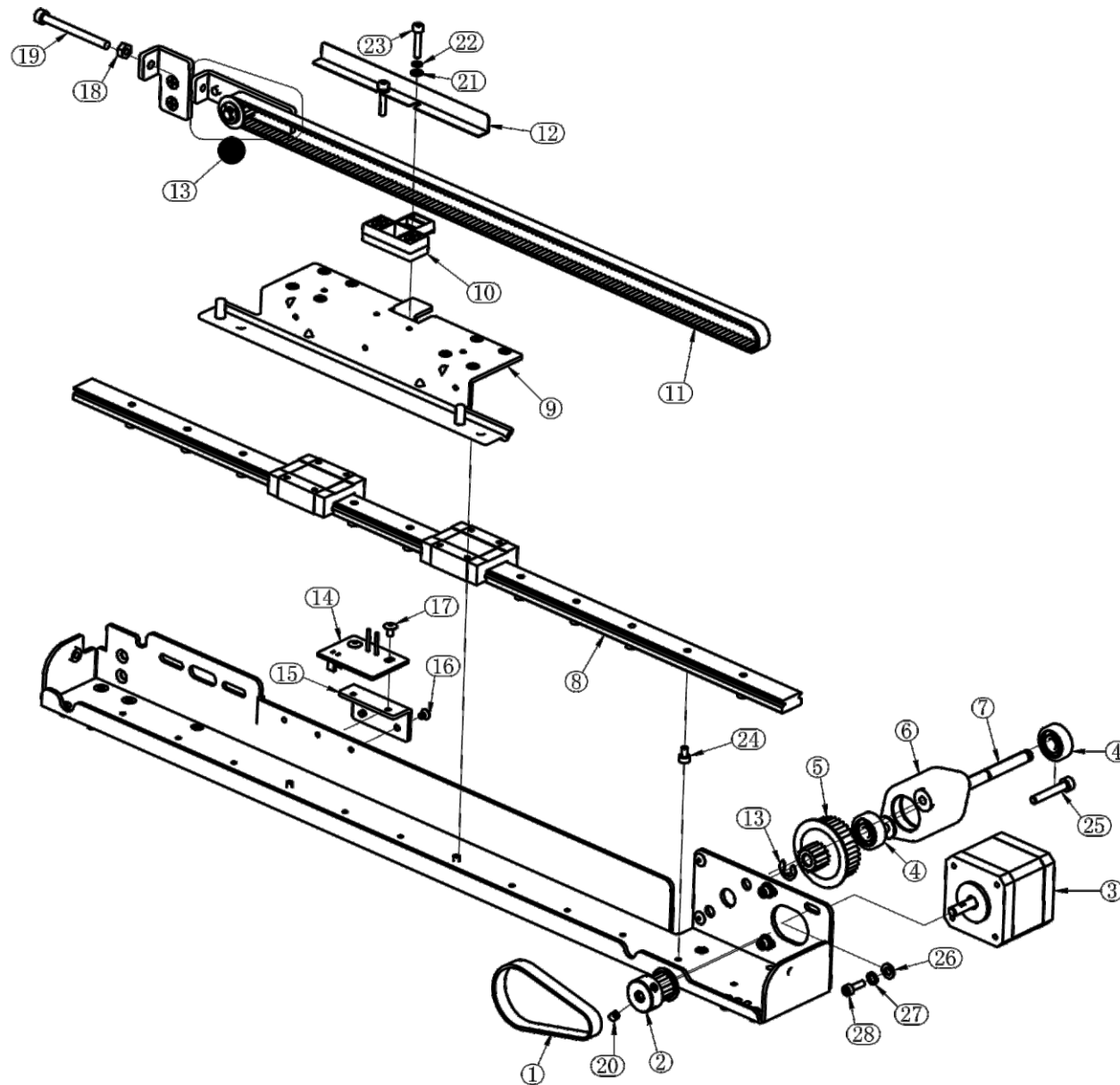



08. X-axis Drive System

06080V3

No.	Serial No.	Part name	Remark
1	3006100194	Timing Belt-Drive-X (3M-168-8)	
2	3006100192	Drive Pulley-X-EM	
3	3006100196VA	Stepper Motor-42HS-X	
4	80030622	Deep Groove Ball Bearing-626ZZ	
5	3006100191	Driven Pulley-X-EM	
6	3006100109	Bearing Base-Driven-X-EM	
7	3006100107	Driven Shaft-X-EM	
8	3006100195	Linear Guide Rail-X-EM-L510	
9	3006100102	Embroidery Frame Connecting Plate-X-EM	
10	3006100104	Timing Belt Pressing Plate-X-EM	
11	3006100193	Timing Belt-X-Driven-EM (3M-783-8)	
12	3006100112	Baffle-Limit-X-EM	
13	3006100161	Left Drive Pulley	
14	3006152106X	Sensor-X Limit	

No.	Serial No.	Part name	Remark
15	3006100111	Sensor Base-Limit-X-EM	
16	80860304	M3*4 Flat Head Philips Screw	
17	80746305	Screw M3*5	
18	80900428	M4 Nut	
19	80813445	M4*45 Hexagon Socket Caphead Screw	
20	80880405	M4*5 Hexagon Socket Set Screw	
21	80900301	M3 Plain Washer	
22	80900318	M3 Spring Washer	
23	80813316	M3*16 Hexagon Socket Caphead Screw	
24	80813408	M4*8 Hexagon Socket Caphead Screw	
25	80813425	M4*25 Hexagon Socket Caphead Screw	
26	80900401	M4 Plain Washer	
27	80900418	M4 Spring Washer	
28	80813310	M3*10 Hexagon Socket Caphead Screw	

09. Needle Bar Case

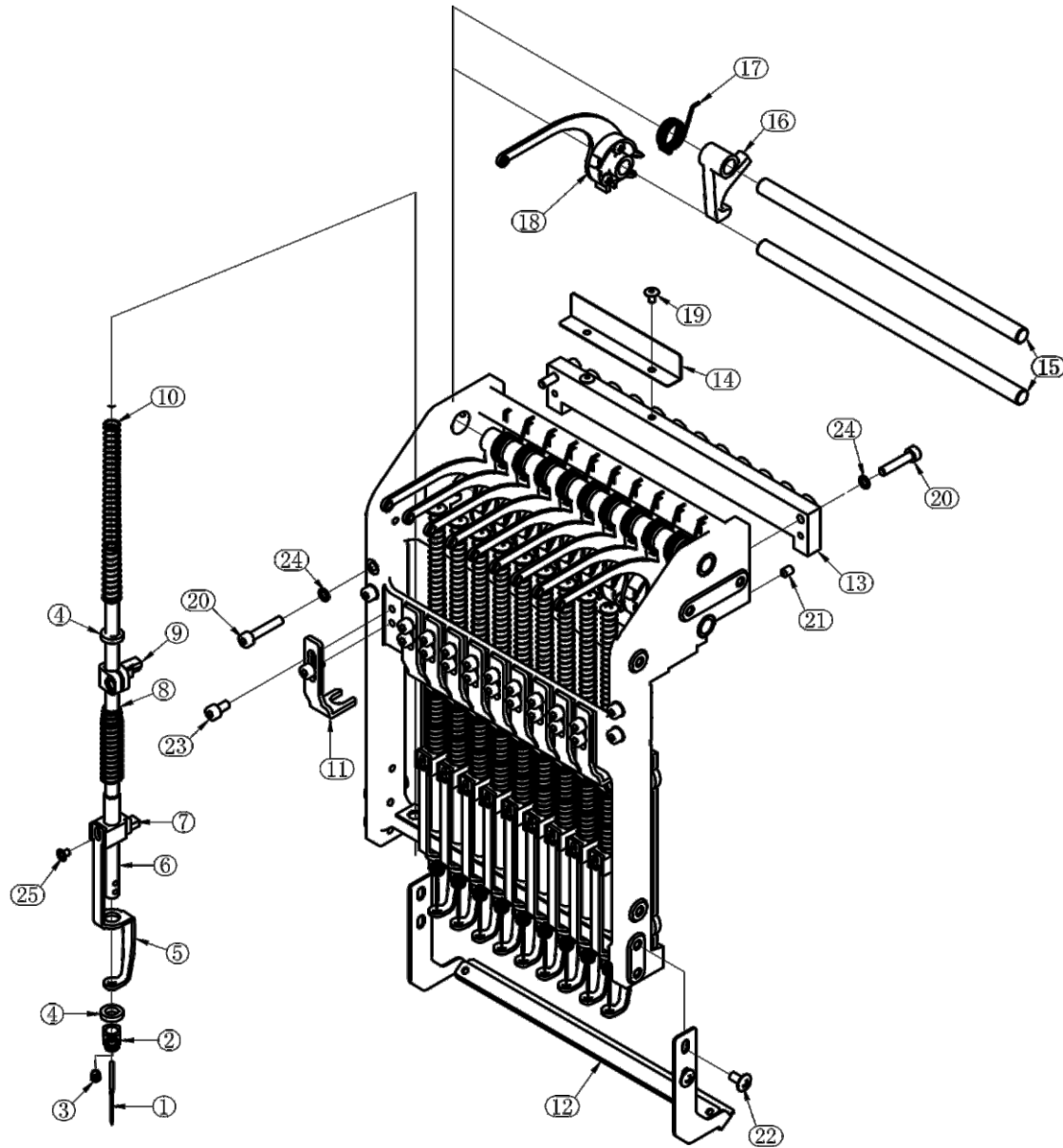



09. Needle Bar Case

06090V3

No.	Serial No.	Part name	Remark
1	80621111	Needle-DBXK5-11	
2	01222181	Needle Clamp	
3	01222183AA	Screw for Needle Clamp	
4	3006081022	Rubber Cushion-Needle Bar	
5	3006081021	Presser Foot-EM	
6	03080160	Needle bar-217	
7	03080104AA	Needle Bar Presser Foot Bushing	
8	03080108	Presser Foot Spring-P	
9	01222106	Needle Bar Connecting Pin	
10	03080102	Needle Bar Spring-P	
11	3006081023	Upper Locating Bracket-Needle Bar-EM	
12	3006081160	Thread Hook Assembly-EM-10	
13	3006040560	Color Change Base Components-Bearing-EM-10	

No.	Serial No.	Part name	Remark
14	3006040517	Baffle-Needle Position Detection	
15	3006081015	Take-up Lever Shaft-EM-10	
16	03081502VA	Take-up Lever B	
17	03081503VA	Position Block Torsional Spring	
18	03081591VA	Take-up Lever A	
19	80746306	Screw M3*6	
20	80813420	M4*20 Hexagon Socket Caphead Screw	
21	80880406	M4*6 Hexagon Socket Set Screw	
22	80746408	Screw M4*8	
23	80813406	M4*6 Hexagon Socket Caphead Screw	
24	80900418	M4 Spring Washer	
25	80746305	Screw M3*5	

10. Middle Thread-Course

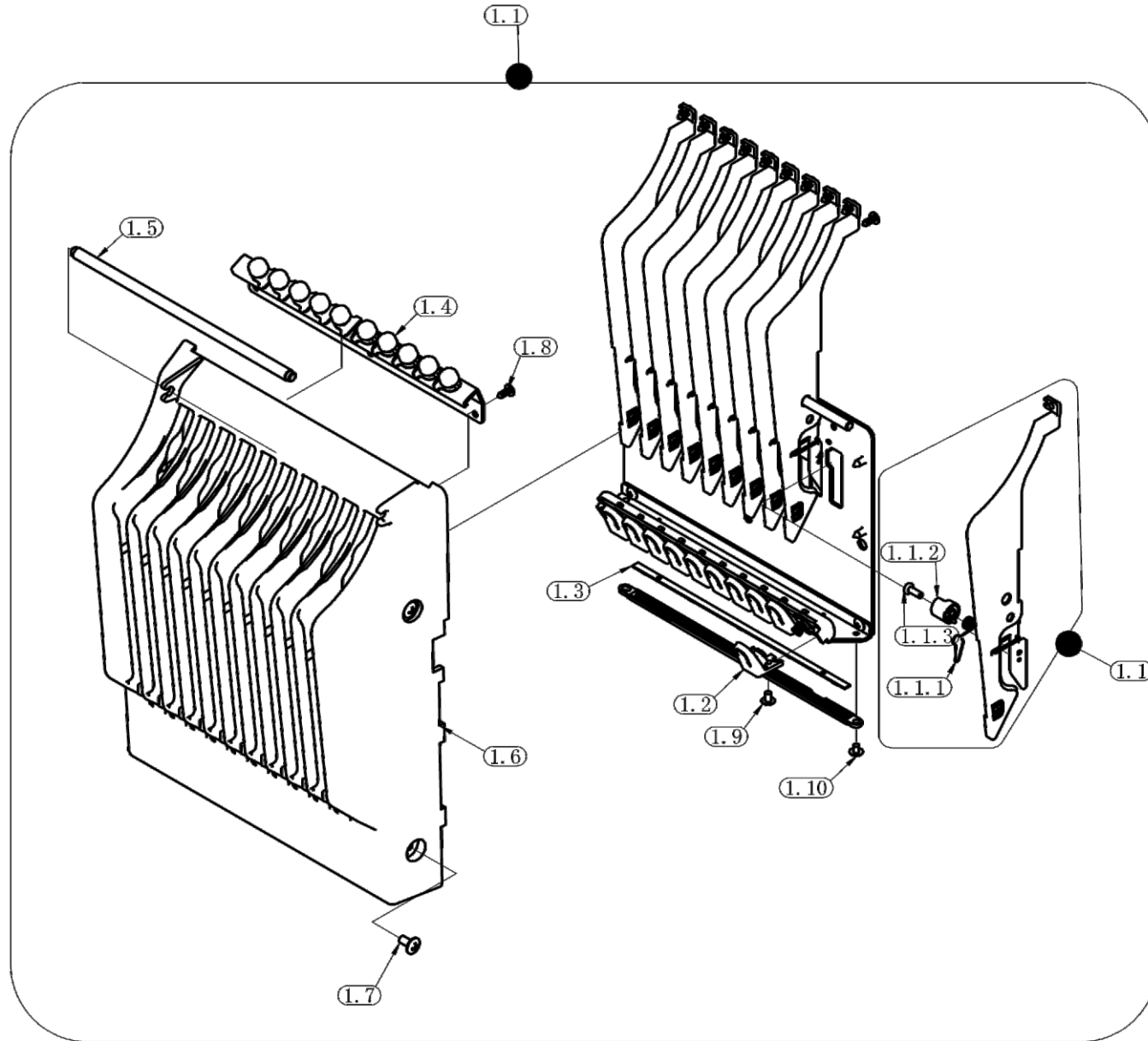



10. Middle Thread-Course

06100V3

No.	Serial No.	Part name	Remark
1	3006081161	Middle Thread-Course Components-EM-10	
1.1	3006081164	Thread-separating Components-EM	
1.1.1	3006081137	Take-up Spring-Middle Thread-course-EM	
1.1.2	3006081103	Take-up Spring Base-Middle Thread-course-EM	
1.1.3	80740306	Screw M3*6-Small Head	
1.2	3006081165	Thread Cutter Components-Lower Thread-course-EM	
1.3	3006152111	LED Light-EM	

No.	Serial No.	Part name	Remark
1.4	3006081162	Thread Guide Components-Middle Thread-Course-EM	
1.5	3006081124	Upper Thread-course Shaft-EM-10	
1.6	3006081101	Middle Thread-course Cover-EM-10	
1.7	80746408	Screw M4*8	
1.8	80700107	Screw-STM3*8	
1.9	80746305	Screw M3*5	
1.10	80746304	Screw M3*4	

11. Control Panel / Support Arm

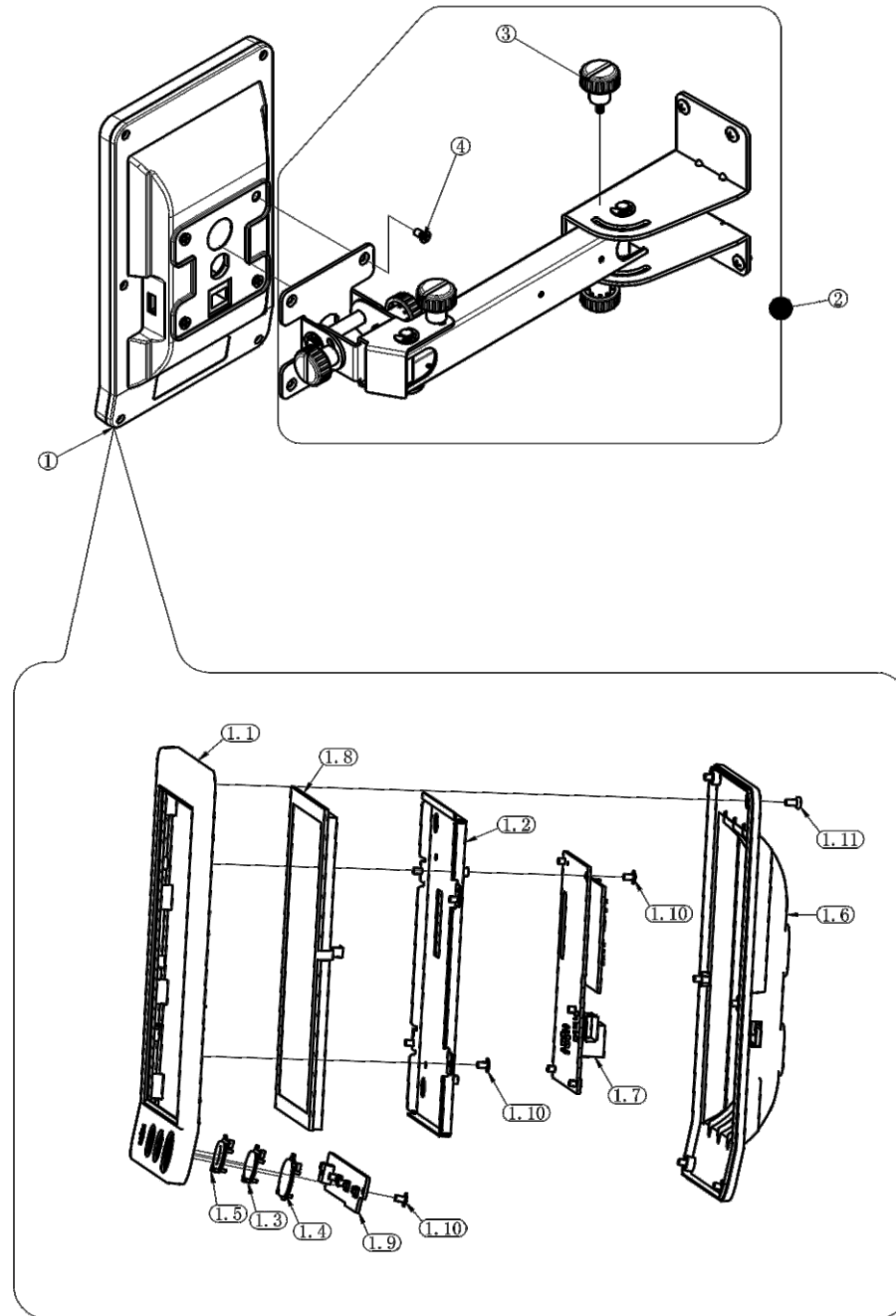



11. Control Panel / Support Arm

06110V3

No.	Serial No.	Part name	Remark
1	3006150160	Control Panel-EM	
1.1	3006150101	Front Cover--Control Panel-7V	
1.2	3006150141	Bracket--Main Board--7V	
1.3	3006150107	100° Button-7V	
1.4	3006150105	Start/Stop Button-7V	
1.5	3006150106	Thread-trimming Button--7V	
1.6	3006150102	Back Cover--Control Panel--7V	
1.7	RCM-SSMFD3V11 +RCMIA678	Main Board-7V	

No.	Serial No.	Part name	Remark
1.8	3006150122	Display Screen--LCD--7V	
1.9	RCM-KEY6V11	Keyboard Plate--7V	
1.10	80746305	Screw M3*5	
1.11	80740306	Screw M3*6-Small Head Philips	
2	3006150161	Panel Bracket Assembly-EM	
3	3006092121	Flat Head	
4	80860408	M4*8 Flat Head Philips Screw	

12. Thread Tray and Thread Stand

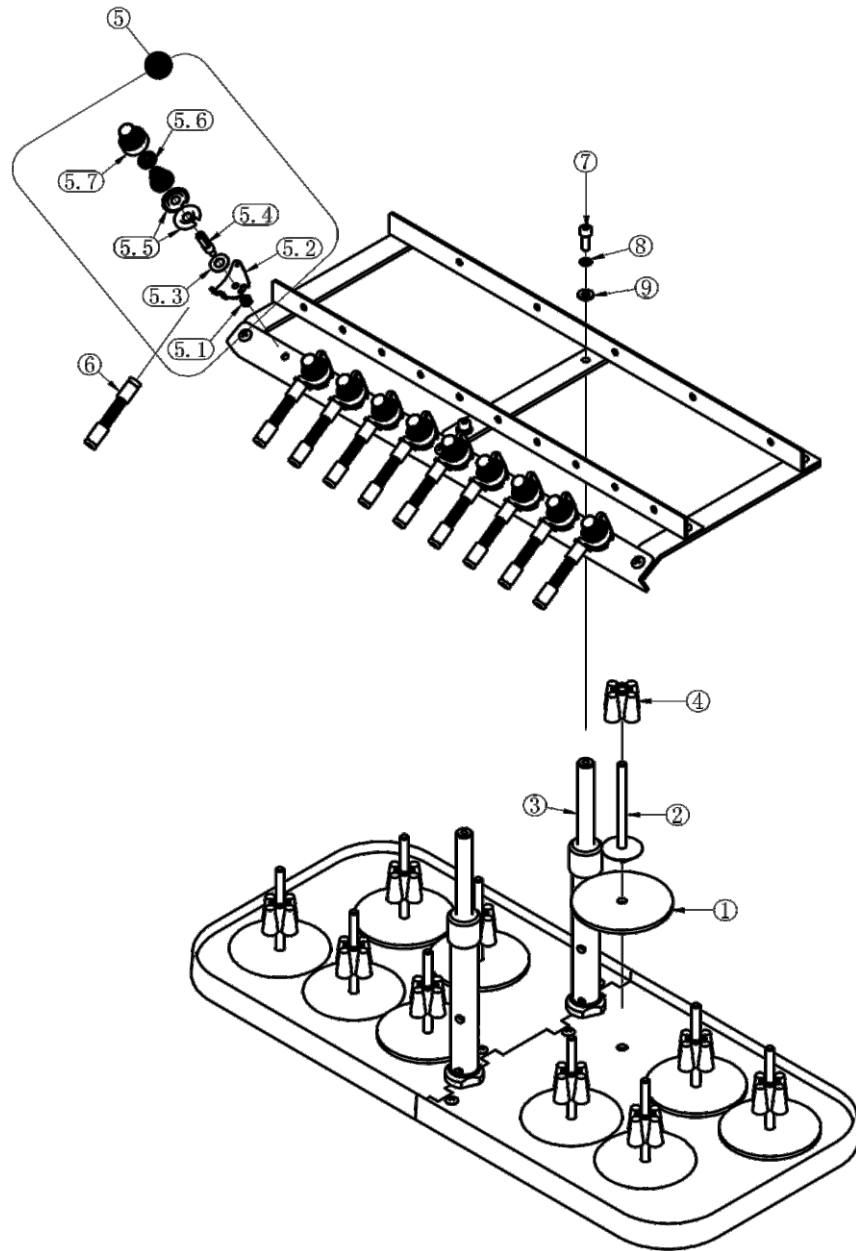



12. Thread Tray and Thread Stand

06120V3

序号	编号	零件名称	备注
1	80211009	线盘海棉垫	
2	80211007	线柱	
3	3006091062	线架立柱套件V2-EM	
4	80211008	线盘垫	
5	3006091561	旋钮组件-线架-EM	
5.1	80900428	螺母-M4不锈钢	
5.2	03141001	引线板-纯轮	
5.3	03141002	毛毡垫-线架旋钮	

No.	Serial No.	Part name	Remark
5.4	3006091510	Pole-Thread Stand--EM	
5.5	03144202	Thread Pressing Plate-Wheel	
5.6	3006140118	Teeth Cover-Thread Tension Base-EM	
5.7	3006140119	Tension Knob-EM	
6	03044361	Plastic Thread Tube Components-Spiral-Transparent	
7	80810514	M5*14 Hexagon Socket Caphead Screw	
8	80900518	M5 Spring Washer	
9	80900501	M5 Plain Washer	

13. Upper Thread Module

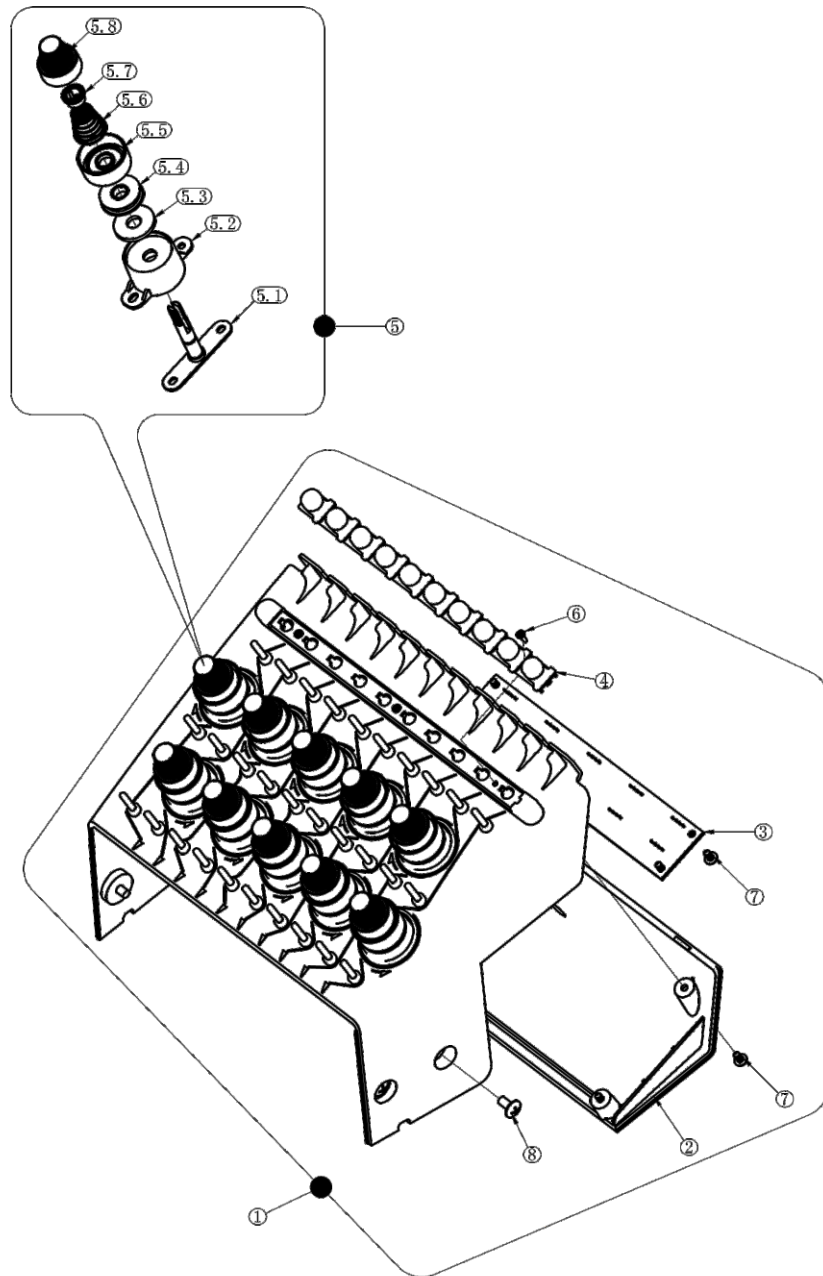



13. Upper Thread Module

06130V3

No.	Serial No.	Part name	Remark
1	3006140160	Upper Thread Tension Base	
2	3006140102	Back Cover-for Upper Tension Base-EM-10	
3	3006151202	Signal Exchange Board-Thread Break Detection-10	
4	3006140162	Thread-guide Components-Thread Tension Base-EM-10	
5	3006140161	Tension Knob Components	
5.1	3006140112	Knob Pole-Thread Tension Base-EM	
5.2	3006140111	Tension Knob Base-EM	
5.3	3006140114	Felt	

No.	Serial No.	Part name	Remark
5.4	3006140163	Thread Break Detection Wheel-EM	
5.5	3006140113	Tension Knob Cover-EM	
5.6	3006140115	Tension Spring	
5.7	3006140118	Teeth Cover	
5.8	3006140119	Tension Knob-EM	
6	80700308	Screw-ST2.9*8	
7	80700107	Screw-ST3*8	
8	80746408	Screw M4*8	

14. Frames and Bracket

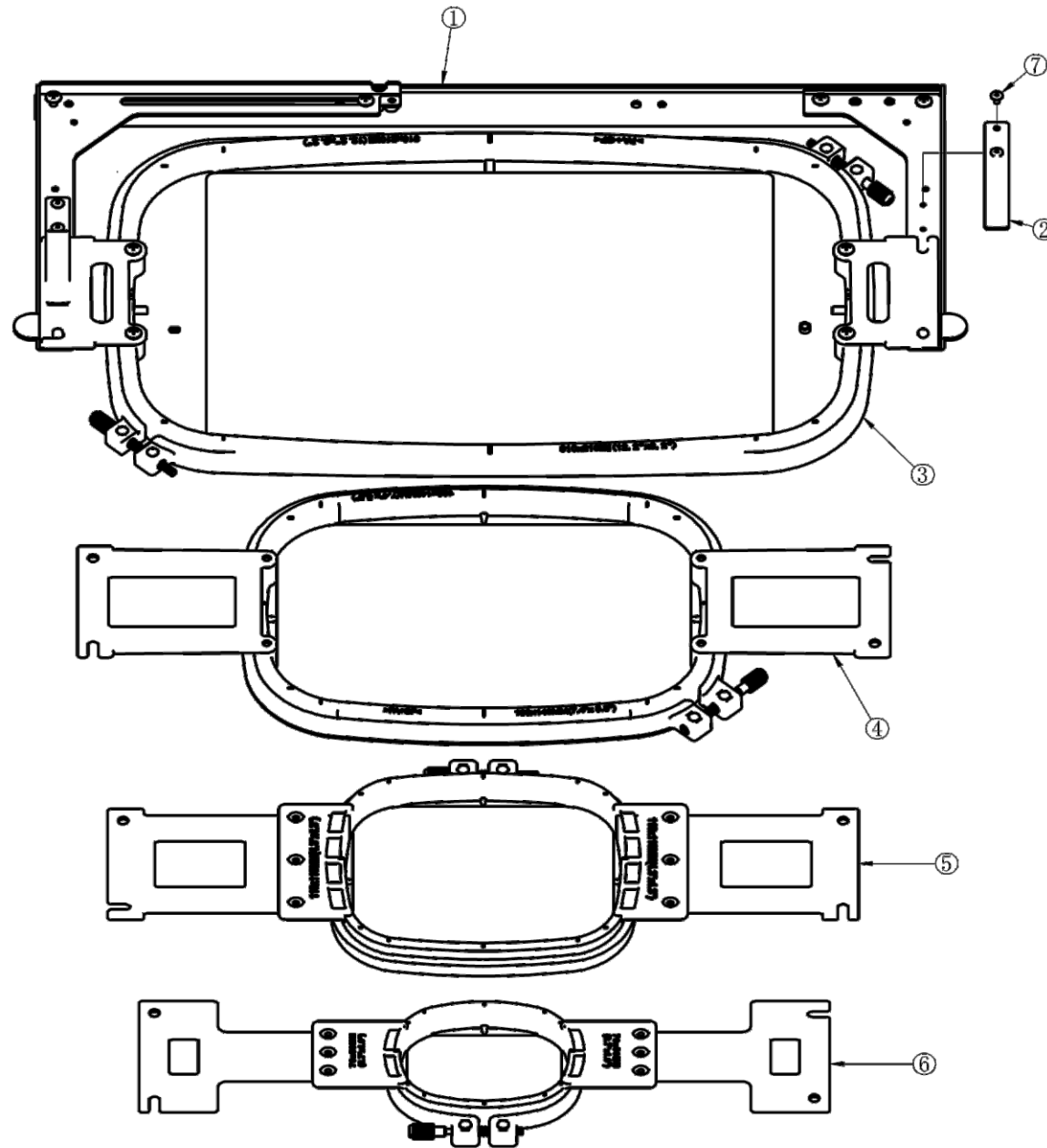



14. Frames and Bracket

06140V3

序号	编号	零件名称	备注
1	3006100260	绣框支架组件-EM	
2	03100205	绣框压片簧	
3	3006171460	成衣框组件-EM-310X210	
4	3006171360	成衣框组件-EM-190X140	
5	3006171260	成衣框组件-EM-110X110	
6	3006171160	成衣框组件-EM-70X50	

No.	Serial No.	Part name	Remark
1	3006100260	Frame Support Components-EM	
2	03100205	Frame Pressing Plate	
3	3006171460	Frame-EM-310*210	
4	3006171360	Frame-EM-190*140	
5	3006171260	Frame-EM-110*110	
6	3006171160	Frame-EM-70*50	

15. Electronic components

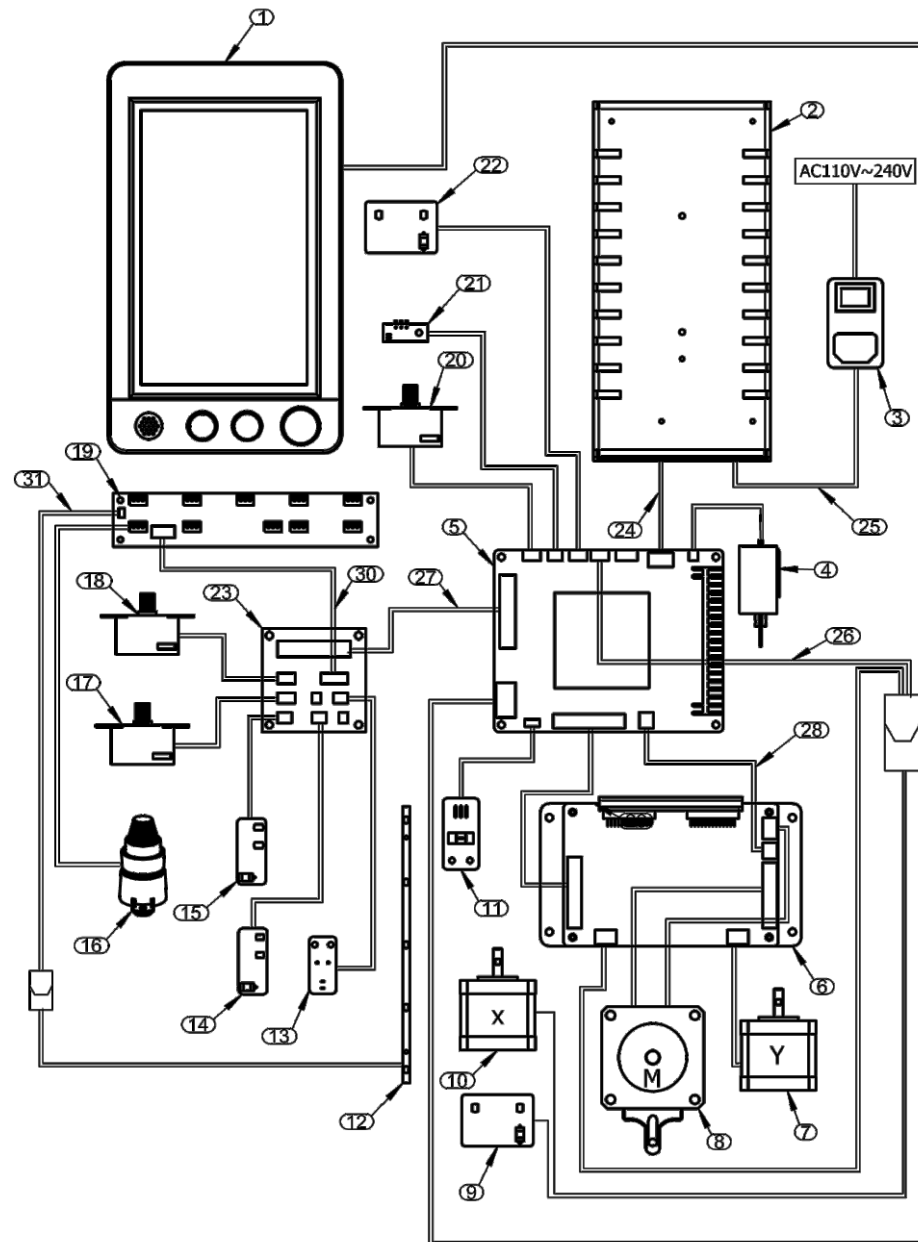



15. Electronic components

06150V3

No.	Serial No.	Part name	Remark
1	3006150160	Control Panel-EM	
2	3006153102VA	Power Supply-DC36-150F	
3	3006153101	Input Socket	
4	3006021560	Picker Solenoid-EM	
5	RCM-SSMFA3V20 +TZA-MB4V15	Multi-function Board+DSP	
6	ED332-LA-1V12	Driver-3 in 1	
7	3006105190	Stepper Motor-60HS3A76-606	
8	3006041296	Main Motor-BLDC60	
9	3006152106X	Sensor-XY Limit	
10	3006100196VA	Stepper Motor-42HS-X	
11	3006152106Y	Sensor-XY Limit	
12	3006152111	Light-LED-EM	
13	3006152107	Sensor Plate for Thread Hook	
14	3006152102	Sensor-Color Change	
15	3006152103	Sensor-Needle Position	

No.	Serial No.	Part name	Remark
16	3006140161	Tension Knob Components	
17	3006040696	Stepper Motor-PM35	
18	3006040596	Stepper Motor-PM35	
19	3006151202	Signal Exchange Board-Thread Break Detection-10	
20	3006021296	Stepper Motor-PM42	
21	3006152105	Sensor-Thread Trimming-J6	
22	3006152104	Sensor-Zero Position-J8	
23	3006151201	Small Exchange Board-Head-7V	
24	3006154201	Power supply	
25	3006154202	Cable from Input to Power Supply	
26	3006105163	Nylon Chain Components-Y-EM	
27	3006154211	Signal Cable-Multi-function Board to Small Exchange Board	
28	3006154203	Cable-Multi-function Board and 3 in 1 Driver	
29	3006154213	Signal Cable-Multi-function Board and 3 in 1 Driver	
30	3006154212	Signal Cable-Small Exchange Board to Thread Break Detection Board	

16. CAP STAND FRAME

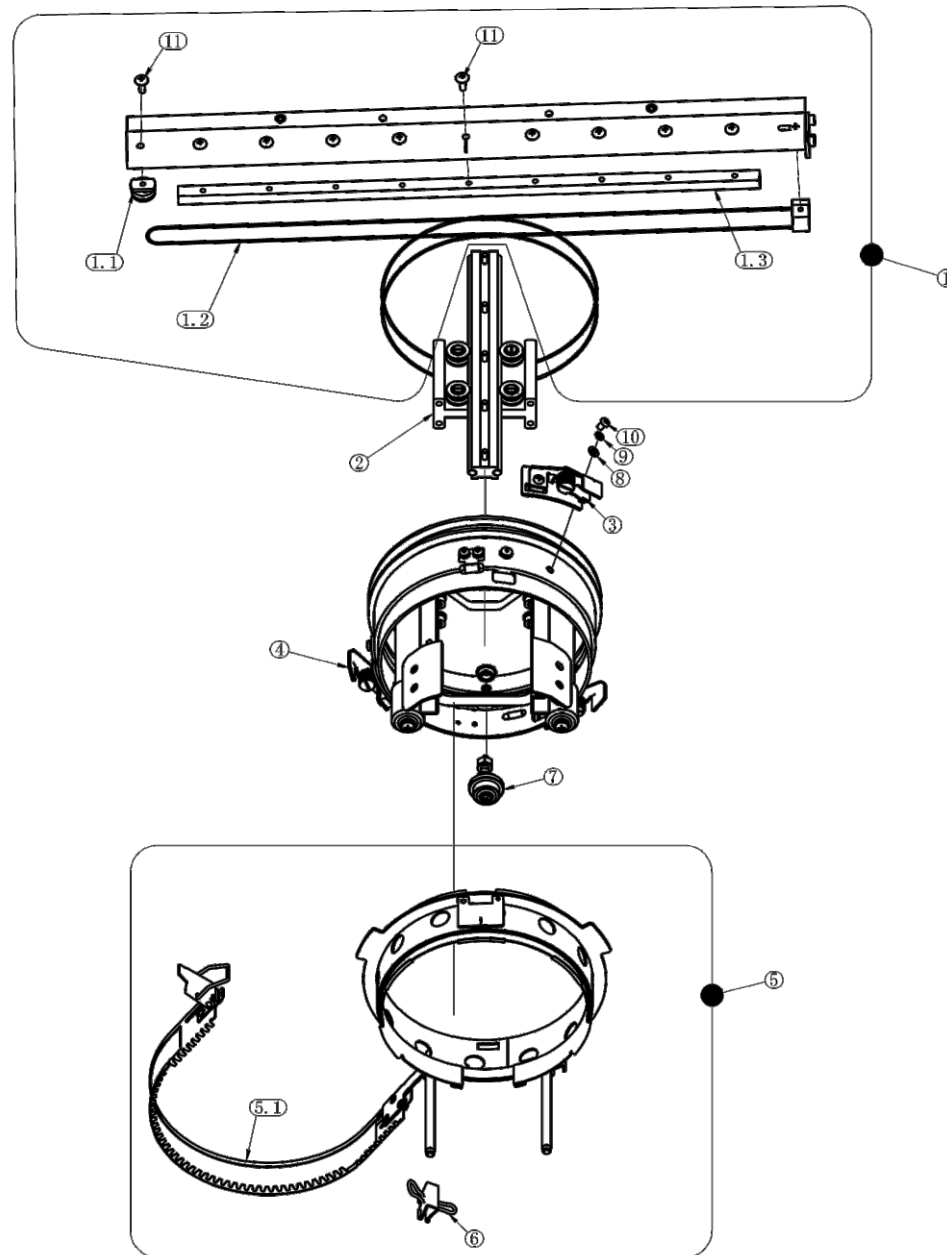



16.帽架部分 CAP STAND FRAME

06160V3

No.	Serial No.	Part name	Remark
1	02815043	Cap Driver Unit-EM	
1.1	02815008	Steel Wire Wheel	
1.2	02815053	Cap Driver Steel Wire Components-EM	
1.3	02815043	Cap Driver Connecting Plate Components-EM	
2	0281506260	Cap Driver Lower Guide Rail Components-EM-A	
3	02810270	Clamp Head Components A	
4	02810271	Clamp Head Components B	
5	02811080	Cap Ring -360	

No.	Serial No.	Part name	Remark
5.1	02811082	Cap Strapping Rod Components	
6	02811055	Clamp - Cap ring	
7	02810161	Eccentric wheel components	
8	80900408	M4 Plain Washer	
9	80900418	M4 Spring Washer	
10	80740401	Screw M4*6-Small Head	
11	80746412	Screw M4*12	



Copyright © RiCOMA (Shenzhen) Co., Ltd. All rights reserved.